



## Zumbadores

Piezoeléctricos



### ZP18

Tras cuadro Ø 18 mm  
Sonido intermitente

Fijación tras cuadro o superficie  
Mínimo consumo  
Tamaño reducido

CÓDIGO	TENSIÓN V	CORRIENTE mA	FRECUENCIA ACÚST. Hz
FC18CC	12/24 c.c. (5-28 v)	20	3500

Dimensiones: (Diámetro x Altura): 28 mm x 25 mm  
 Construcción: ABS negro  
 Montaje: Centrado para abertura de Ø 18 mm / superficie  
 Terminal: Cable  
 Salida de sonido: Frontal

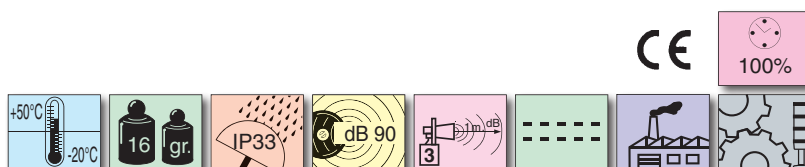

FC28CC



FC28CCA  
FC28ICA

### ZP28

Tras cuadro Ø 28 mm  
Sonido continuo y/o intermitente

Fijación tras cuadro  
Mínimo consumo  
Sonido continuo o intermitente seleccionable (versión 24V c.c.)  
Volumen regulable por medio de rejilla frontal giratoria

CÓDIGO	TENSIÓN V	CORRIENTE mA	FRECUENCIA ACÚST. Hz
FC28CC	24 c.c. (16-28 v)	25	2400
FC28 <input type="checkbox"/> CA	230 c.c.a. (48-230 v)	10	2400

▲ C - sonido continuo / I - sonido intermitente

Dimensiones: (Diámetro x Profundidad): 48 mm x 43 mm (FC28CC)  
 (Diámetro x Profundidad): 48 mm x 63 mm (FC28CCA / FC28ICA)  
 Construcción: ABS negro  
 Montaje: Centrado para abertura de Ø 28 mm  
 Terminal: 6,3 x 0,8 mm  
 Salida de sonido: Frontal

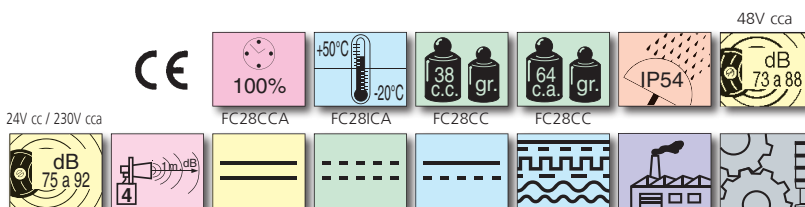



## Diagramas técnicos

### ZP18

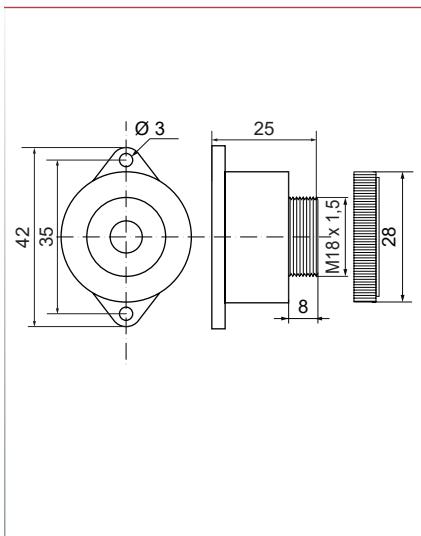

### ZP28

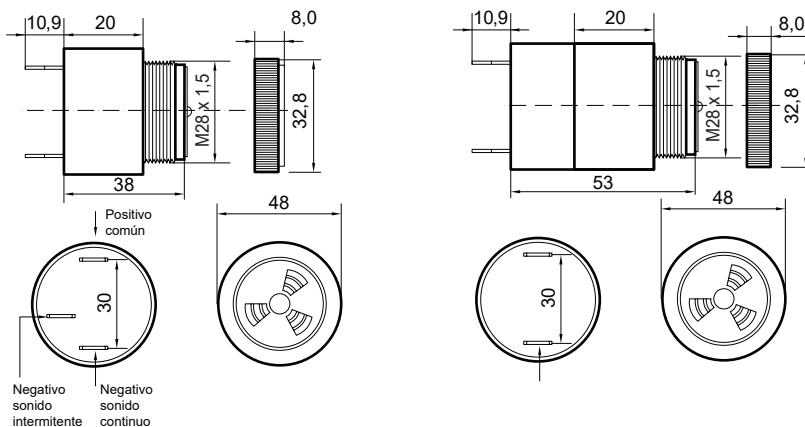



## Variación teórica de la intensidad sonora respecto a la distancia del emisor (dB)

Es importante recordar que una Señal Acústica reduce en 6 dB su percepción sonora con el doble de la distancia

Ejemplo: 100 dB a 1 metro, significa 94 dB a 2 metros.  
94 dB a 2 metros, significa 80 dB a 10 metros.

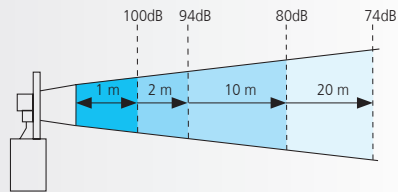

### DISTANCIA EN METROS

		1	2	3	5	10	20	30	50	100	200	300	500	1000	2000	3000	5000
8	150	144	140	136	130	124	120	116	110	104	100	96	90	84	80	76	
	148	142	138	134	128	122	118	114	108	102	98	94	88	82	78	74	
	146	140	136	132	126	120	116	112	106	100	96	92	86	80	76	72	
	144	138	134	130	124	118	114	110	104	98	94	90	84	78	74	70	
	142	136	132	128	122	116	112	108	102	96	92	88	82	76	72	68	
	140	134	130	126	120	114	110	106	100	94	90	86	80	74	70	66	
	138	132	128	124	118	112	108	104	98	92	88	84	78	72	68	64	
	136	130	126	122	116	110	106	102	96	90	86	82	76	70	66	62	
	134	128	124	120	114	108	104	100	94	88	84	80	74	68	64	60	
	132	126	122	118	112	106	102	98	92	86	82	78	72	66	62	58	
7	130	124	120	116	110	104	100	96	90	84	80	76	70	64	60	56	
	128	122	118	114	108	102	98	94	88	82	78	74	68	62	58	54	
	126	120	116	112	106	100	96	92	86	80	76	72	66	60	56	52	
	124	118	114	110	104	98	94	90	84	78	74	70	64	58	54	50	
	122	116	112	108	102	96	92	88	82	76	72	68	62	56	52	48	
	120	114	110	106	100	94	90	86	80	74	70	66	60	54	50	46	
	118	112	108	104	98	92	88	84	78	72	68	64	58	52	48	44	
	116	110	106	102	96	90	86	82	76	70	66	62	56	50	46	42	
	114	108	104	100	94	88	84	80	74	68	64	60	54	48	44	40	
	112	106	102	98	92	86	82	78	72	66	62	58	52	46	42	38	
5	110	104	100	96	90	84	80	76	70	64	60	56	50	44	40		
	108	102	98	94	88	82	78	74	68	62	58	54	48	42	38		
	106	100	96	92	86	80	76	72	66	60	56	52	46	40			
	104	98	94	90	84	78	74	70	64	58	54	50	44	38			
	102	96	92	88	82	76	72	68	62	56	52	48	42				
	100	94	90	86	80	74	70	66	60	54	50	46	40				
	98	92	88	84	78	72	68	64	58	52	48	44	38				
	96	90	86	82	76	70	66	62	56	50	46	42					
	94	88	84	80	74	68	64	60	54	48	44	40					
	92	86	82	78	72	66	62	58	52	46	42	38					
3	90	84	80	76	70	64	60	56	50	44	40						
	88	82	78	74	68	62	58	54	48	42							
	86	80	76	72	66	60	56	52	46	40							
	84	78	74	70	64	58	54	50	44	38							
	82	76	72	68	62	56	52	48	42								
	80	74	70	66	60	54	50	46	40								
	75	69	65	61	55	49	45	41									
	70	64	60	56	50	44	40	36									
	65	59	55	51	45	39	35										

PRESIÓN SONORA EN dB [A]

