

INSTRUCTION & SERVICE MANUAL

DL105H AlertAlight Combined Sounder LED Beacons

- -40°C to +66C (-40°F to 151°F)
- Type 4 / 4X / 3R / 13, IP66
- 2.1Kg (4.62lb)
- CE, UKCA
- All units UL Listed.

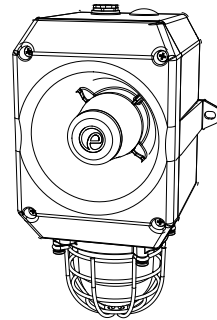

Unit Type Code	Nominal Voltage	Voltage Range	Nominal Sounder Current*	Nominal Beacon Current*	Nominal SPL	Max SPL	Average SPL
DL105HDC024	#12 V dc	10-14Vdc	17mA	79.5mA	105.3dB(A) Tone 44 @ 1m	110.9dB(A) Tone 4 @ 1m	105.2dB(A) All tones @1m
	24V dc	16-33Vdc (Regulated)	33.5mA	87mA			
DL105HDC048	48V dc	48-60Vdc	113mA	60mA			
DL105HAC230	115V ac	48 - 260Vac 50/60Hz	25mA	34mA			
	230V ac		17mA	19mA			

*Nominal current at nominal voltage, Tone 12 / 1Hz Flash Pattern; #Factory Default setting 24Vdc, beacon customer setttable to 12Vdc

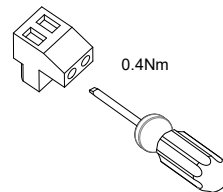
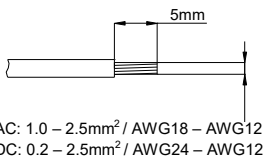

Attention: Installation must be carried out by an electrician in compliance with the latest codes and regulations.

Attention: L'installation doit être effectuée par un électricien conformément aux derniers codes et réglementations.

Achtung: Die Installation muss von einem Elektriker gemäß den neuesten Vorschriften und Bestimmungen durchgeführt werden.

Attenzione: L'installazione deve essere eseguita da un elettricista in conformità con i codici e le normative più recenti.

Atención: La instalación debe ser realizada por un electricista de acuerdo con los últimos códigos y regulaciones.

Atenção: A instalação deve ser realizada por um electricista de acordo com os códigos e regulamentos mais recentes.

Внимание: установка должна выполняться электриком в соответствии с последними нормами и правилами.

Attention: Disconnect from power source before installation or service to prevent electric shock

Attention: Débranchez-le de la source d'alimentation avant l'installation ou l'entretien pour éviter tout choc électrique.

Achtung: Vor Installation oder Wartung von der Stromquelle trennen, um einen Stromschlag zu vermeiden.

Attenzione: scollegare dall'alimentazione prima dell'installazione o dell'assistenza per evitare scosse elettriche.

Atención: desconéctelo de la fuente de alimentación antes de la instalación o el servicio para evitar descargas eléctricas.

Atenção: Desconecte da fonte de alimentação antes da instalação ou serviço para evitar choque elétrico

Внимание: отключите от источника питания перед установкой или обслуживанием, чтобы предотвратить поражение электрическим током.



AC

(See D218-06-205)

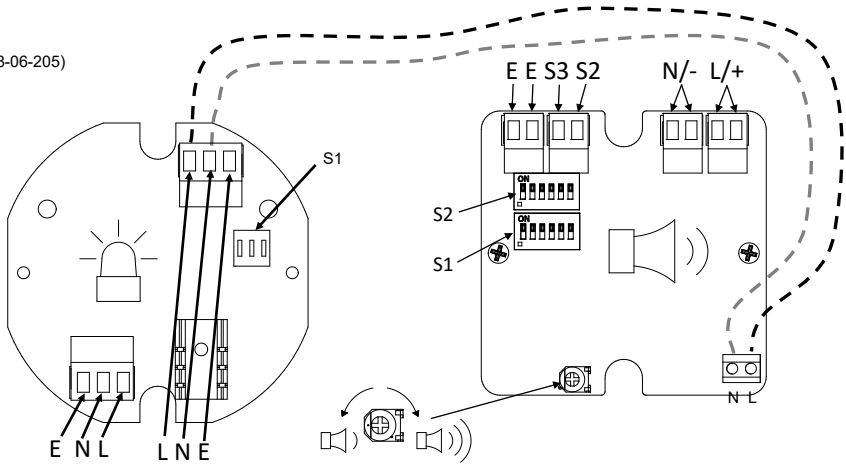

DC

(See D218-06-201)

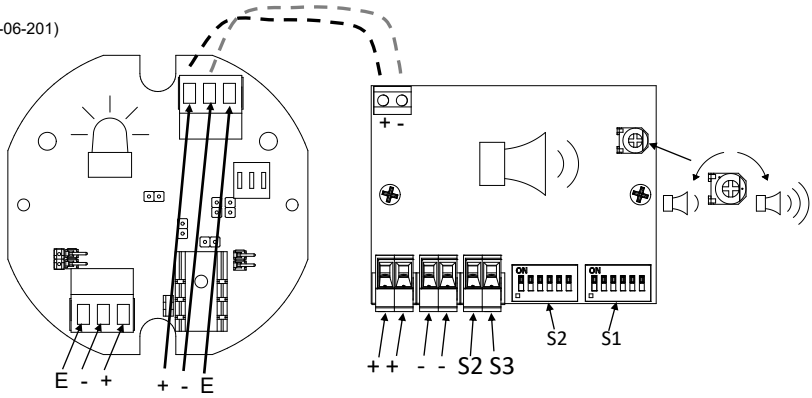

(AC & DC, See D221-95-001)

Default = S2 - Tone 1

Default = S1 - Tone 44

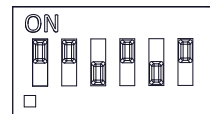
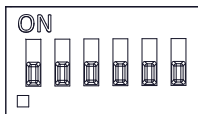

(ON = 1, OFF = 0)

INSTRUCTION & SERVICE MANUAL

DL105H AlertAlight Combined Sounder LED Beacons

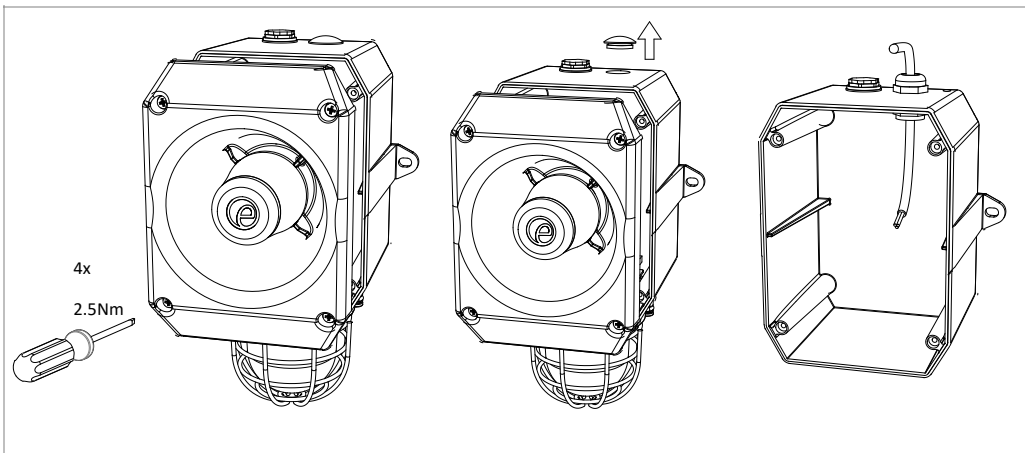

For DL105HAC units wire an Earth to the E terminal on the PCBA in order to Earth the metal housing.

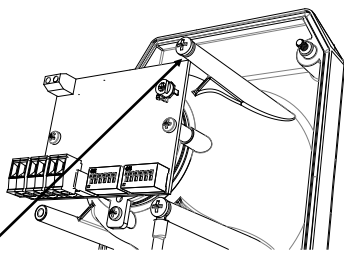

For DL105HDC units, using a ring terminal, fit an Earth to the shown location underneath the M4 screw and M4 spring washer. This point shall not be used for any other purpose (e.g. ground bonding).

D105HDC024 Beacon PCBA (24VDC Mode – Default Setting)

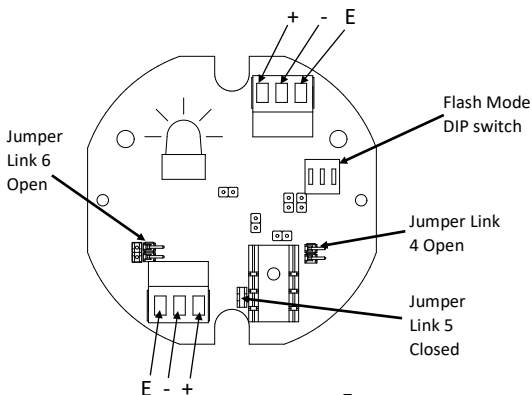

Jumper Setting	Jumper Link 4	Jumper Link 5	Jumper Link 6
24VDC Mode (Default)	Open	Closed	Open
12VDC Mode (Customer Set)	Closed	Open	Closed

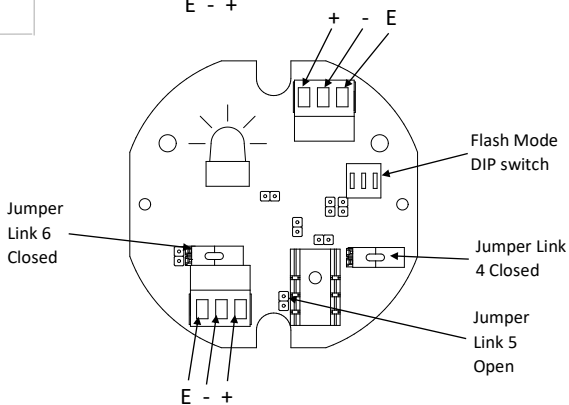

D105HDC024 Beacon PCBA (12VDC Mode – Customer to Set)

S1 - LED Flash Mode Settings (AC & DC)

The Flash Mode Dip Switch can be changed to set the desired flash pattern

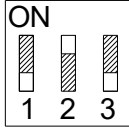

Flash Mode DIP Switch – Shown with 1-OFF, 2-ON, 3-OFF (0 1 0), This denotes Flash mode 1Hz. For further flash modes refer to table:

Switch Setting	Flash Mode
0 0 0	Steady on
1 0 0	Blinking
0 1 0	Flashing 1Hz*
1 1 0	Flashing 1.5Hz*
0 0 1	Flashing - Double Strike
1 0 1	Flashing - Triple Strike
0 1 1	Flashing 2Hz*
1 1 1	Flashing - Temporal

- All models are approved for use as Audible Signal and Visual Appliance for use as General Signaling: UL464A & CSA C22.2 No 205-17
- Type 4 / 4X / 3R / 13, IP66
- -40°C to +66°C / -40°C to +151°F

General Signaling Canada:

DL105HDC: -40°C to +55°C / -40°F to +131°F

DL105HAC: -40°C to +40°C / -40°F to +104°F

- To maintain Ingress Protection, cable entries must be fitted with suitably rated cable glands or stopping plugs
- Mounting - Units can be mounted using the 2-off 10 x 7mm obround holes in the mounting lugs.
- EOL Monitoring (DC Only): End of Line Devices may be fitted between the +ve & -ve terminals of the PCBA. Please ensure that the device legs meet the wire size range stated for the connection terminals and are fitted correctly in order to avoid a short. Refer to the compatible control panel specification for EOL device values and ratings



Model	Nominal Voltage	Voltage Range	Nominal Operating Current*		Max Operating RMS#	
			Beacon	Sounder	Beacon	Sounder
DL105HDC024	12V dc	10-14Vdc	79.5mA	17mA	168mA	125mA
	24V dc	16-33Vdc	87mA	33.5mA	183mA	
DL105HDC048	48V dc	48-60Vdc	60mA	113mA	115mA	
DL105HAC230	115V ac	48 - 260Vac 50/60Hz	34mA	25mA	166mA	42.5mA
	230V ac		19mA	17mA		

*Nominal Voltage, 1Hz Flash Pattern & Tone 12; #Worst-case input voltage and worst case flash pattern



Attention: Installation must be carried out by an electrician in compliance with the National Electrical Code, NFPA 70 or CSA 22.1 Canadian Electrical Code, Part I, Safety Standard for Electrical Installations, Section 32. / L'installation doit exclusivement être réalisée par du personnel qualifié, conformément au code national d'électricité américain, NFPA 70 ou CSA 22.1 Code canadien de l'électricité, première partie, norme de sécurité relative aux installations électriques, Section 32

ISSUE	MOD No.	REASON - INITIAL - DATE
A		INTRODUCTION RSR - 11/05/2021

--- WIRING LINKING BEACON & SOUNDER
FACTORY FITTED

OPTIONAL LINE MONITORING RESISTOR, CUSTOMER SUPPLIED.
RECOMMENDED MINIMUM VALUES:
14V MAX SYSTEM = 120Ω MIN, 2W MIN OR 1KΩ MIN, 0.5W MIN
28V MAX SYSTEM = 470Ω MIN, 2W MIN OR 2.4KΩ MIN, 0.5W MIN

Linked Sounder & Beacon Activation (Default)

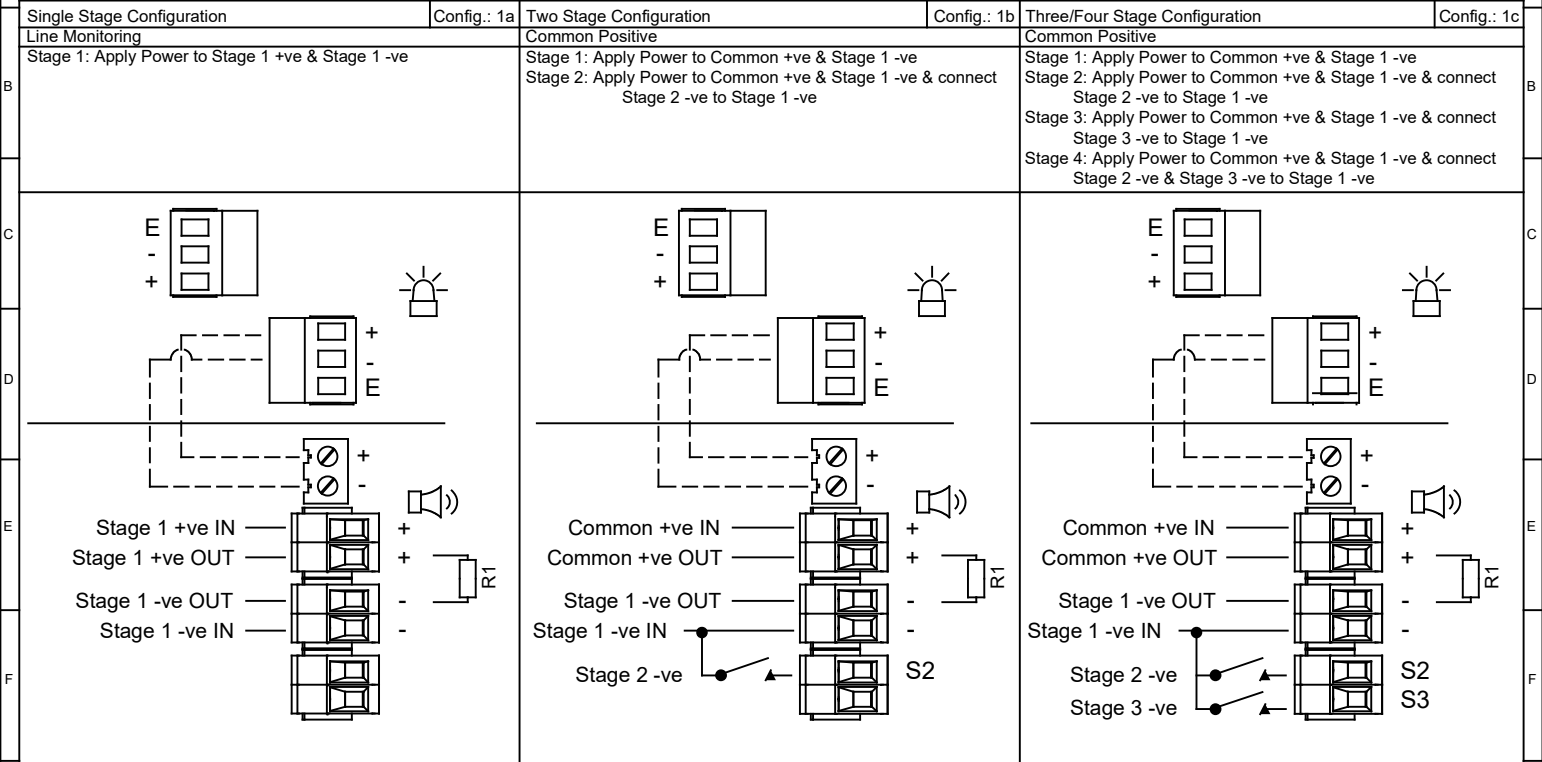

DRAWING TO BS8888:2000 GEOMETRIC TOLERANCES TO ISO1101:1983 LINEAR DIMENSIONAL TOLS ANGULAR DIMENSIONAL TOLS	DRAWN	DATE	SURFACE FINISH	WEIGHT (Kg)
	R.S.RAIT	16/03/2021		
	CHECKED	DATE		
STANDARDS	B.ISARD	16/03/2021	MATERIAL	ALTERNATIVE MATERIAL
	APPROVED	DATE		
	R.N.POTTS	16/03/2021		
ALERTALARM RANGE				

THIS DRAWING AND ANY INFORMATION OR DESCRIPTIVE MATTER THEREIN IS COMMUNICATED IN CONFIDENCE AND IS THE COPYRIGHT PROPERTY OF EUROPEAN SAFETY SYSTEMS LTD. NEITHER THE WHOLE OR ANY EXTRACT MAY BE DISCLOSED, LOANED, COPIED OR USED FOR MANUFACTURING OR TENDERING PURPOSES WITHOUT THEIR WRITTEN CONSENT.

EUROPEAN SAFETY SYSTEMS LTD.
AS PER LATEST DATE OF ISSUE SHOWN ABOVE

e2s
warning signals

EUROPEAN SAFETY SYSTEMS LTD
IMPRESS HOUSE
MANSELL ROAD
LONDON W3 7QH
WWW.E2S.COM

ALL DIMENSIONS IN MM IF IN DOUBT, ASK - DO NOT SCALE			A3
TITLE AL100H, AL105NH & DL105H DC COMBINED SOUNDER & LED WIRING DIAGRAMS			
SCALE	SHEET	DRAWING NUMBER	
NTS	1 of 2	D218-06-251	

OPTIONAL LINE MONITORING RESISTOR, CUSTOMER SUPPLIED,
RECOMMENDED MINIMUM VALUES:
14V MAX SYSTEM = 120Ω MIN, 2W MIN OR 1KΩ MIN, 0.5W MIN
28V MAX SYSTEM = 470Ω MIN, 2W MIN OR 2.4KΩ MIN, 0.5W MIN

ISSUE	MOD No.	REASON - INITIAL - DATE
A		INTRODUCTION RSR - 11/05/2021

Independent Sounder & Beacon Activation (Remove Link Wires)

Single Stage Configuration	Config.: 5a	Two Stage Configuration	Config.: 5b	Three/Four Stage Configuration	Config.: 5c
Line Monitoring		Common Positive		Common Positive	
Stage 1: Apply Power to Stage 1 -ve & Stage 1 +ve		Stage 1: Apply Power to Common +ve & Stage 1 -ve Stage 2: Apply Power to Common +ve & Stage 1 -ve & connect Stage 2 -ve to Stage 1 -ve		Stage 1: Apply Power to Common +ve & Stage 1 -ve Stage 2: Apply Power to Common +ve & Stage 1 -ve & connect Stage 2 -ve to Stage 1 -ve Stage 3: Apply Power to Common +ve & Stage 1 -ve & connect Stage 3 -ve to Stage 1 -ve Stage 4: Apply Power to Common +ve & Stage 1 -ve & connect Stage 2 -ve & Stage 3 -ve to Stage 1 -ve	

DRAWING TO BS8888:2000 GEOMETRIC TOLERANCES TO ISO1101:1983 LINEAR DIMENSIONAL TOLS ANGULAR DIMENSIONAL TOLS	DRAWN	DATE
	R.S.RAIT	16/03/2021
	CHECKED	DATE
STANDARDS	B.ISARD	16/03/2021
	APPROVED	DATE
	R.N.POTTS	16/03/2021
ALERTALARM RANGE		

SURFACE FINISH	WEIGHT (Kg)
MATERIAL	
ALTERNATIVE MATERIAL	

THIS DRAWING AND ANY INFORMATION OR DESCRIPTIVE MATTER THEREIN IS COMMUNICATED IN CONFIDENCE AND IS THE COPYRIGHT PROPERTY OF EUROPEAN SAFETY SYSTEMS LTD. NEITHER THE WHOLE OR ANY EXTRACT MAY BE DISCLOSED, LOANED, COPIED OR USED FOR MANUFACTURING OR TENDERING PURPOSES WITHOUT THEIR WRITTEN CONSENT.

EUROPEAN SAFETY SYSTEMS LTD.
AS PER LATEST DATE OF ISSUE SHOWN ABOVE

e2s waiting signals

EUROPEAN SAFETY SYSTEMS LTD
IMPRESS HOUSE
MANSELL ROAD
LONDON W3 7QH
WWW.E2S.COM

ALL DIMENSIONS IN MM IF IN DOUBT, ASK - DO NOT SCALE		A3
TITLE AL100H, AL105NH & DL105H DC COMBINED SOUNDER & LED WIRING DIAGRAMS		
SCALE	SHEET	DRAWING NUMBER
NTS	2 OF 2	D218-06-251

ISSUE	MOD No	REASON - INITIAL - DATE
A		INTRODUCTION RSR - 16/04/2021

--- WIRING LINKING BEACON & SOUNDER
FACTORY FITTED

SWITCHES FOR STAGE OPERATION
CUSTOMER SUPPLIED

Linked Sounder & Beacon Activation (Default)

Single Stage Configuration Config.: 1a Two/Three Stage Sounder Configuration Config.: 1b

Stage 1: Apply Power to Stage 1 Live & Stage 1 Neutral

Stage 1: Apply Power to Live & Neutral
Stage 2: Apply Power to Live & Neutral & connect Stage 2 to Live
Stage 3: Apply Power to Live & Neutral & connect Stage 3 to Live

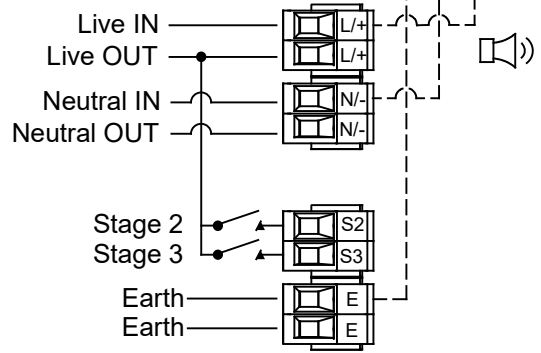
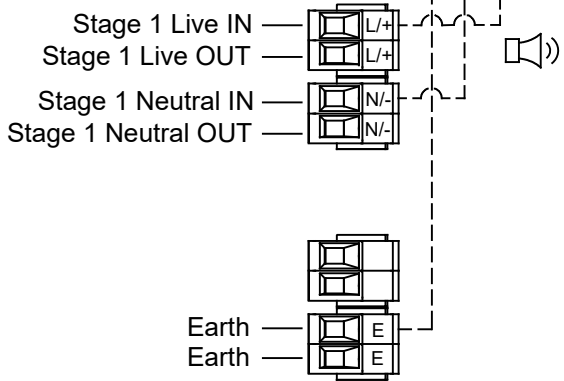
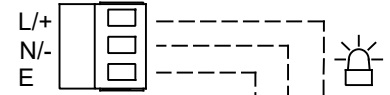
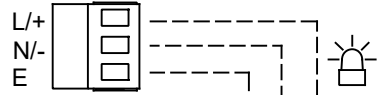
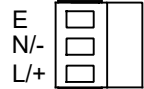
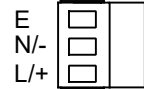

DRAWING TO BS8888:2000 GEOMETRIC TOLERANCES TO ISO1101:1983 LINEAR DIMENSIONAL TOLS ANGULAR DIMENSIONAL TOLS	DRAWN	DATE	SURFACE FINISH	WEIGHT (Kg)
	R.S.RAIT	16/03/2021		
	CHECKED	DATE		
STANDARDS ALERTALARM RANGE	B.ISARD	16/03/2021	MATERIAL	ALTERNATIVE MATERIAL
	APPROVED	DATE		
	R.N.POTTS	16/03/2021		

AS PER LATEST DATE OF ISSUE SHOWN ABOVE

THIS DRAWING AND ANY INFORMATION OR DESCRIPTIVE MATTER THEREIN IS COMMUNICATED IN CONFIDENCE AND IS THE COPYRIGHT PROPERTY OF EUROPEAN SAFETY SYSTEMS LTD. NEITHER THE WHOLE OR ANY EXTRACT MAY BE DISCLOSED, LOANED, COPIED OR USED FOR MANUFACTURING OR TENDERING PURPOSES WITHOUT THEIR WRITTEN CONSENT.

EUROPEAN SAFETY SYSTEMS LTD.
AS PER LATEST DATE OF ISSUE SHOWN ABOVE

EUROPEAN SAFETY SYSTEMS LTD
IMPRESS HOUSE
MANSELL ROAD
LONDON W3 7QH
WWW.E2S.COM

ALL DIMENSIONS IN MM IF IN DOUBT, ASK - DO NOT SCALE			A3
TITLE AL100H, AL105NH & DL105H AC COMBINED SOUNDER & LED WIRING DIAGRAMS			
SCALE	SHEET	DRAWING NUMBER	
NTS	1 of 2	D218-06-255	

ISSUE	MOD No	REASON - INITIAL - DATE
A		INTRODUCTION RSR - 16/04/2021

--- WIRING LINKING BEACON & SOUNDER
FACTORY FITTED

SWITCHES FOR STAGE OPERATION
CUSTOMER SUPPLIED

Independent Sounder & Beacon Activation (Remove Link Wires)

Single Stage Configuration Config.: 2a Two/Three Stage Sounder Configuration Config.: 2b

Stage 1: Apply Power to Stage 1 Live & Stage 1 Neutral

Stage 1: Apply Power to Live & Neutral
Stage 2: Apply Power to Live & Neutral & connect Stage 2 to Live
Stage 3: Apply Power to Live & Neutral & connect Stage 3 to Live

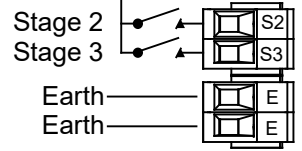
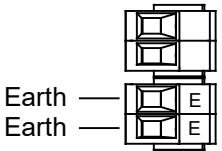
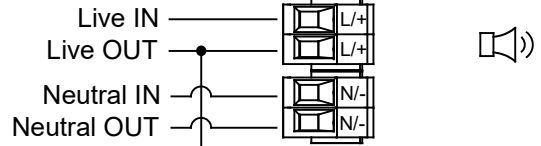
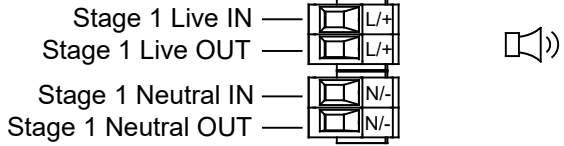
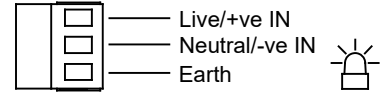
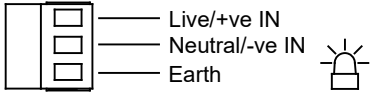
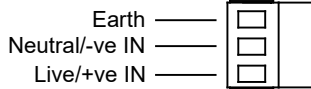
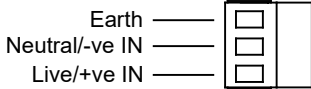

DRAWING TO BS8888:2000 GEOMETRIC TOLERANCES TO ISO1101:1983 LINEAR DIMENSIONAL TOLS ANGULAR DIMENSIONAL TOLS	DRAWN	DATE	SURFACE FINISH	WEIGHT (Kg)
	R.S.RAIT	16/03/2021		
	CHECKED	DATE		
STANDARDS ALERTALARM RANGE	B.ISARD	16/03/2021	MATERIAL	
	APPROVED	DATE	ALTERNATIVE MATERIAL	
	R.N.POTTS	16/03/2021		

G	MATERIAL	
		ALTERNATIVE MATERIAL

THIS DRAWING AND ANY INFORMATION OR DESCRIPTIVE MATTER THEREIN IS COMMUNICATED IN CONFIDENCE AND IS THE COPYRIGHT PROPERTY OF EUROPEAN SAFETY SYSTEMS LTD. NEITHER THE WHOLE OR ANY EXTRACT MAY BE DISCLOSED, LOANED, COPIED OR USED FOR MANUFACTURING OR TENDERING PURPOSES WITHOUT THEIR WRITTEN CONSENT.

EUROPEAN SAFETY SYSTEMS LTD.
AS PER LATEST DATE OF ISSUE SHOWN ABOVE

e2s
wiring signals

EUROPEAN SAFETY SYSTEMS LTD
IMPRESS HOUSE
MANSELL ROAD
LONDON W3 7QH
WWW.E2S.COM

ALL DIMENSIONS IN MM IF IN DOUBT, ASK - DO NOT SCALE			A3
TITLE AL 100H, AL105NH & DL105H AC COMBINED SOUNDER & LED WIRING DIAGRAMS			
SCALE	SHEET	DRAWING NUMBER	
NTS	2 OF 2	D218-06-255	

Stage 1 Set DIP SW 1 Tone No.	Tone Description	Tone Visual	Stage 1 & 2 DIP SW 1/2 Settings 1 2 3 4 5 6	Stage 3 Set DIP SW 1 (S3)	Stage 4 Set DIP SW 1 (S2 + S3)
1	1000Hz PFEER Toxic Gas		0 0 0 0 0 0	2	44
2	1200/500Hz @ 1Hz DIN /PFEER P.T.A.P.		1 0 0 0 0 0	3	44
3	1000Hz @ 0.5Hz(1s on, 1s off) PFEER Gen. Alarm		0 1 0 0 0 0	2	44
4	1.4KHz-1.6KHz 1s, 1.6KHz-1.4KHz 0.5s NF C 48-265		1 1 0 0 0 0	24	1
5	544Hz(100mS)/440Hz (400mS) NF S 32-001		0 0 1 0 0 0	19	1
6	1500/500Hz - (0.5s on, 0.5s off) x3 + 1s gap AS4428		1 0 1 0 0 0	44	1
7	500-1500Hz Sweeping 2 sec on 1 sec off AS4428		0 1 1 0 0 0	44	1
8	500/1200Hz @ 0.26Hz (3.3son, 0.5s off) Netherlands - NEN 2575		1 1 1 0 0 0	24	35
9	1000Hz (1s on, 1s off)x7 + (7s on, 1s off) IMO Code 1a		0 0 0 1 0 0	34	1
10	1000Hz (1s on, 1s off)x7 + (7s on, 1s off) IMO Code 1a		1 0 0 1 0 0	34	1
11	420Hz(0.5s on, 0.5s off)x3 + 1s gap ISO 8201 Temporal Pattern		0 1 0 1 0 0	1	8
12	1000Hz(0.5s on, 0.5s off)x3 + 1s gap ISO 8201 Temporal Pattern		1 1 0 1 0 0	1	8
13	422/775Hz - (0.85 on, 0.5 off) x3 + 1s gap NFPA - Temporal Coded		0 0 1 1 0 0	1	8
14	1000/2000Hz @ 1Hz Singapore		1 0 1 1 0 0	3	35
15	300Hz Continuous (f=300)		0 1 1 1 0 0	24	1
16	440Hz Continuous (f=440)		1 1 1 1 0 0	24	1
17	470Hz Continuous (f=470)		0 0 0 0 1 0	24	8
18	500Hz Continuous IMO code 2 (Low) (f=500)		1 0 0 0 1 0	24	8
19	554Hz Continuous (f=554)		0 1 0 0 1 0	24	8
20	660Hz Continuous (f=660)		1 1 0 0 1 0	24	35
21	800Hz IMO code 2 (High) (f=800)		0 1 0 1 0 0	24	35
22	1200Hz Continuous (f=1200)		1 0 1 0 1 0	24	35
23	2000Hz Continuous (f=2000)		0 1 1 0 1 0	3	35
24	2400Hz Continuous (f=2400)		1 1 1 0 1 0	20	35
25	440Hz @0.83Hz (50 cycles/minute) Intermittent (f=440, a=0.6, b=0.6)		0 0 0 1 1 0	44	8
26	470Hz @0.9Hz - 1.1s Intermittent (f=470, a=0.55, b=0.55)		1 0 0 1 1 0	44	8
27	470Hz @5Hz - (5 cycles/second) Intermittent (f=470, a=0.1, b=0.1)		0 1 0 1 1 0	44	8
28	544Hz @ 1.14Hz - 0.875s Intermittent (f=470, a=0.43, b=0.44)		1 1 0 1 1 0	24	8
29	655Hz @ 0.875Hz Intermittent (f=655, a=0.57, b=0.57)		0 0 1 1 1 0	24	8
30	660Hz @0.28Hz - 1.8sec on, 1.8sec off Intermittent (f=660, a=1.8, b=1.8)		1 0 1 1 1 0	24	8
31	660Hz @3.34Hz - 150mS on, 150mS off Intermittent (f=660, a=0.15, b=0.15)		0 1 1 1 1 0	24	8
32	745Hz @ 1Hz Intermittent (f=745, a=0.5, b=0.5)		1 1 1 1 1 0	24	8
33	800Hz - 0.25sec on, 1 sec off Intermittent (f=800, a=0.25, b=1)		0 0 0 0 0 1	24	8
34	800Hz @ 2Hz IMO code 3.a (High) Intermittent (f=800, a=0.25, b=0.25)		1 0 0 0 0 1	24	19
35	1000Hz @ 1Hz Intermittent (f=1000, a=0.5, b=0.5)		0 1 0 0 0 1	24	19
36	2400Hz @ 1Hz Intermittent (f=2400, a=0.5, b=0.5)		1 1 0 0 0 1	24	19
37	2900Hz @ 5Hz Intermittent (f=2900, a=0.1, b=0.1)		0 0 1 0 0 1	24	19
38	363/518Hz @ 1Hz Alternating (f=363, f1=518, a=0.1)		1 0 1 0 0 1	8	19
39	450/500Hz @ 2Hz Alternating (f=450, f1=500, a=0.25)		0 1 1 0 0 1	8	19
40	554/440Hz @ 1Hz Alternating (f=440, f1=554, a=0.5)		1 1 1 0 0 1	24	19
41	554/440Hz @ 0.625Hz Alternating (f=440, f1=554, a=0.8)		0 0 0 1 0 1	8	19
42	561/760Hz @0.83Hz (50 cycles/minute) Alternating (f=561, f1=760, a=0.6)		1 0 0 1 0 1	8	19
43	780/600Hz @ 0.96Hz Alternating (f=600, f1=780, a=0.52)		0 1 0 1 0 1	8	19
44	800/1000Hz @ 2Hz Alternating (f=800, f1=1000, a=0.25)		1 1 0 1 0 1	24	19
45	970/800Hz @ 2Hz Alternating (f=800, f1=970, a=0.25)		0 0 1 1 0 1	8	19
46	800/1000Hz @ 0.875Hz Alternating (f=800, f1=1000, a=0.57)		1 0 1 1 0 1	24	19
47	2400/2900Hz @ 2Hz Alternating (f=2400, f1=2900, a=0.25)		0 0 1 1 0 1	24	19
48	500/1200Hz @ 0.3Hz Sweeping (f=500, f1=1200, a=3.34)		1 1 1 1 0 1	24	12
49	560/1055Hz @ 0.18Hz Sweeping (f=560, f1=1055, a=5.47)		0 0 0 0 1 1	24	12
50	560/1055Hz @ 3.3Hz Sweeping (f=560, f1=1055, a=0.3)		1 0 0 0 1 1	24	12
51	600/1250Hz @ 0.125Hz Sweeping (f=600, f1=1250, a=8)		0 1 0 0 1 1	24	12
52	660/1200Hz @ 1Hz Sweeping (f=660, f1=1200, a=1)		1 1 0 0 1 1	24	12
53	800/1000Hz @ 1Hz Sweeping (f=800, f1=1000, a=1)		0 1 0 0 1 1	24	12
54	800/1000Hz @ 7Hz Sweeping (f=800, f1=1000, a=0.14)		1 0 1 0 1 1	24	12
55	800/1000Hz @ 50Hz Sweeping (f=800, f1=1000, a=0.02)		0 1 0 1 0 1	24	12
56	2400/2900Hz @ 7Hz Sweeping (f=2400, f1=2900, a=0.14)		1 1 1 0 1 1	24	12
57	2400/2900Hz @ 1Hz Sweeping (f=2400, f1=2900, a=1)		0 0 0 1 1 1	24	12
58	2400/2900Hz @ 50Hz Sweeping (f=2400, f1=2900, a=0.02)		1 0 0 1 1 1	24	12
59	2500/3000Hz @ 2Hz Sweeping (f=2500, f1=3000, a=0.5)		0 1 0 1 1 1	24	12
60	2500/3000Hz @ 7.7Hz Sweeping (f=2500, f1=3000, a=0.13)		1 1 0 1 1 1	24	12
61	800Hz Motor Siren (f=800, a=1.6)		0 0 1 1 1 1	24	12
62	1200Hz Motor Siren (f=1200, a=2)		1 0 1 1 1 1	24	12
63	2400Hz Motor Siren (f=2400, a=1.7)		0 1 1 1 1 1	24	12
64	Simulated Bell		1 1 1 1 1 1	21	12